

HAMEX  
PRECISION TOOLS

Only the Best

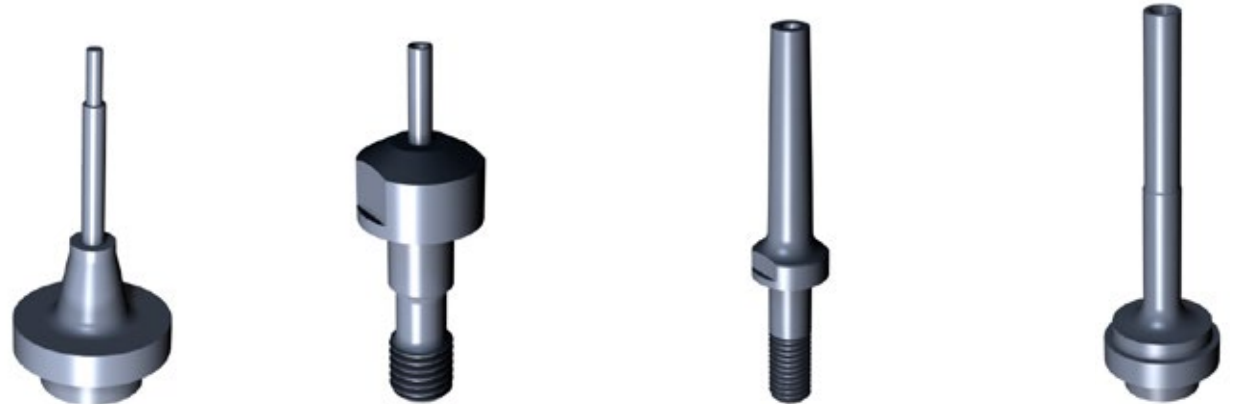

# To Get Perfect Results You Need Grinding Quills of Exceptional Quality

Hamex has built its reputation by fabricating the market's finest grinding quills for over thirty years. That is why we are continually selected as first-source supplier to manufacturers and users of CNC grinding machines around the globe.

## High Quality and Fast Throughput

The market wants quality, and wants it fast. Manufacturers depend on machines for craftsmanship nowadays, and high quality depends on superior tools. A new type of craftsmanship is involved in the making of tools. Grinding wheels of new abrasive materials and bondings have improved mechanical properties. But they do tougher work than earlier tool generations. So while cubic boron nitride (CBN) grinds more effectively than silicon carbide does, it also requires a higher grinding pressure.

As new manufacturing processes evolve, grinding quills become increasingly critical for high precision operations. They must satisfy unconditional criteria:

- + Rigidity to withstand high pressure
- + Perfect rotation to achieve speeds up to 200 000 rpm

## The Whole is the Sum of its Parts

All machining processes depend on smooth interaction within the system. The grinding quill, the collet, the wheel clamp, and the CNC machine itself must merge to a perfect entity to ensure a perfect result. A quill runout of 2 to 3 microns can achieve a finish of 6 to 8 microns.

Nowadays, a quill is a vital component in the grinding process. By choosing the optimal grade of tungsten carbide, the quill's properties can be tailored to meet each specific task.

## Only the Best

Taken together, the market demands place heavy responsibility on the quill fabricator. There must be machining resources for processing in a variety of metals while adhering to minimum tolerances. There must be know-how concerning tungsten carbide grades. There must be quality control resources to enable precision checking of each individual quill.

A grinding quill is part of a customized solution, unique for each customer. A quill must meet the requirements of grinding wheel manufacturers as well as equipment manufacturing machines for numeric control. We have built our reputation on superior quality and reliable products. We have experience of grinding quills that suit machines from world leaders.

For all customer demands and for all makes of machine, Hamex is the tool fabricator you can rely on. By means of our flexible manufacturing services, we assure top-class quills to meet all specifications, allowing our clients to keep their own commercial promises further down the line: grinding with the highest attainable precision and efficiency.



# Hamex Products are Working Around the World

Grinding quills are only one range of Hamex products. We specialize in carbide tools and our goal is always the same: to provide high quality tools and to give customer satisfaction.

Users of our tools are found on all five continents. We take a measure of pride in the fact that each year new clients from many countries choose us as first source supplier.

We invite inquiries about our capabilities and the product alternatives we are able to offer.

